

Multi-functional machining with strong clamping system and new technology

KGT

- Double-sided inserts of KGT reduces machining cost
- Strong clamping system ensures stable and accurate machining
- New grade and new technology provide superior tool life
- Various tooling solutions of the KGT improve productivity
- The foreside and clearance face of the KGT insert having cutting edges are optimal for grooving, parting-off, turning and facing with reducing processing time
- Three-dimensional chip breaker ensures excellent chip control in various applications
- The KGT inserts with various chip breakers are available for wide application range
- Special cutting edges are available for quotation

Insert code system

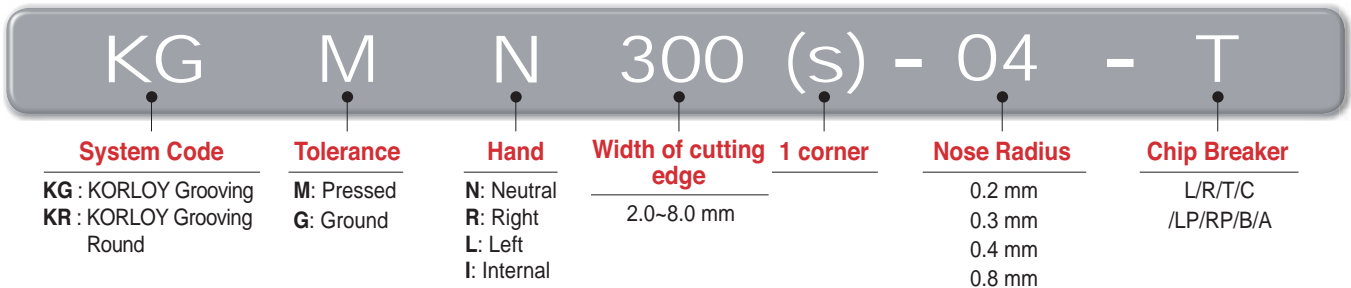



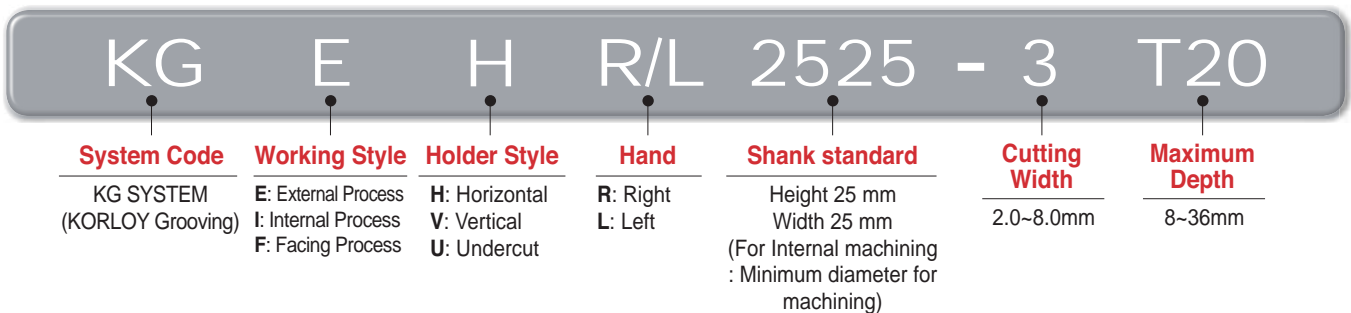



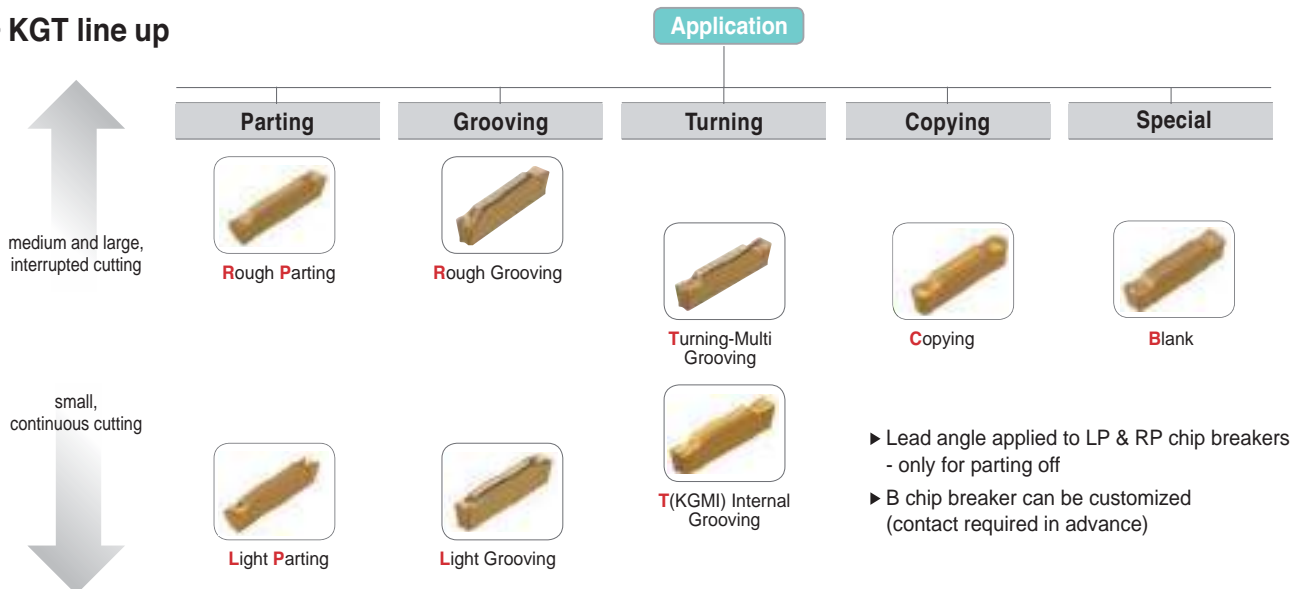



Holder code system



KGT line up



Recommended insert

Designation	Geometry	Picture	Application									
			For external machining			For face grooving		For Internal machining		Copying	For relief	Special machining
			Parting	Grooving	Turning	Grooving	Turning	Grooving	Turning	Copying	Relieving	Special
KGMN	L Light Grooving		○	◎		○						
	R Rough Grooving		○	◎		○						
	T Turning-Multi Grooving		○	◎	◎	◎	◎					
KGMI	T Internal Grooving							◎	◎			
KRMN	C Copying									◎	◎	
KGMRL	LP Light Parting		◎									
	RP Rough Parting		◎									
KGGN	B Blank			○								◎
	A Aluminum Grooving		○	◎	○							
KRGN	A Aluminum Profiling									◎	◎	
KRMI	C Copying									◎	◎	

◎ First choice, ○ Second choice

Features

Front View



- Strong clamping → Higher machining reliability
- Self-centering → Higher accuracy
- Anti-chattering design → Fine surface finish

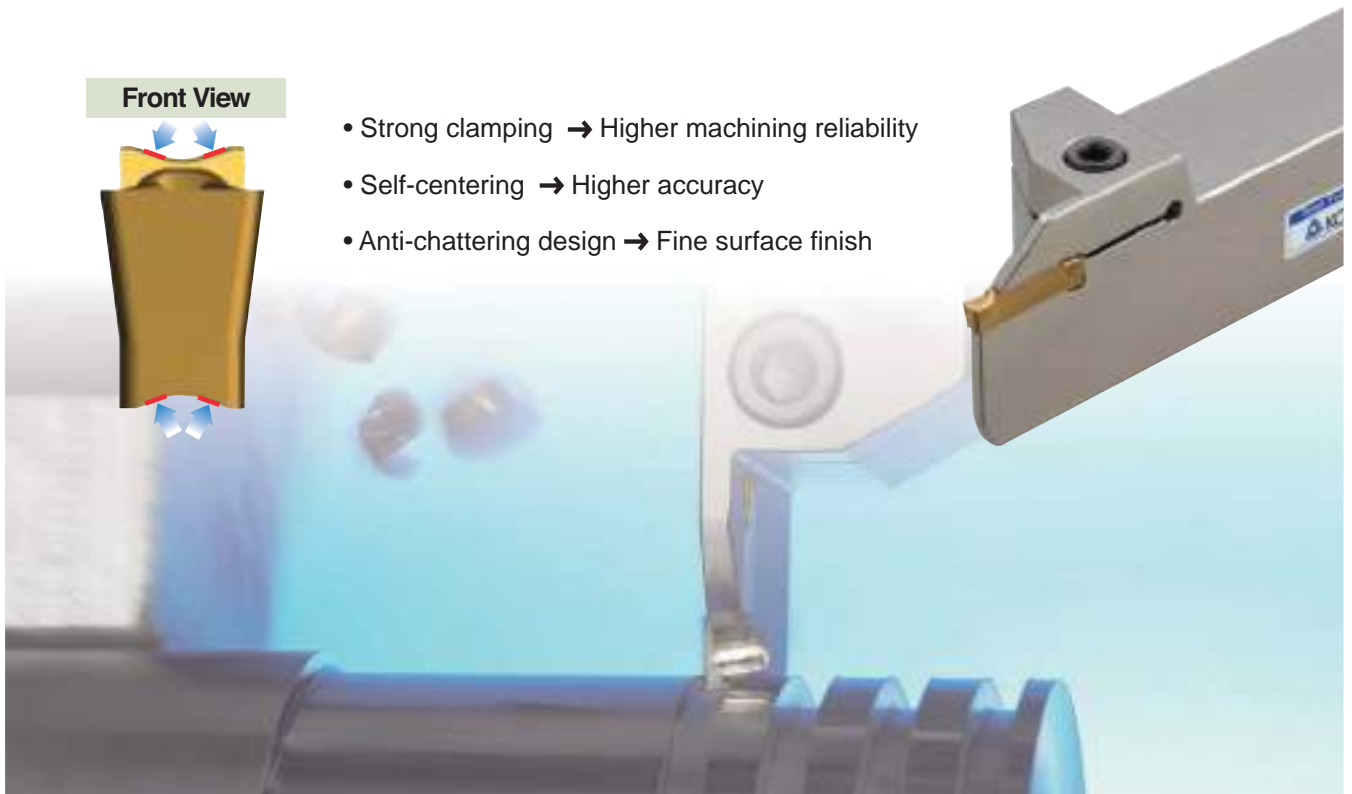

C/B guide

L For Light Grooving

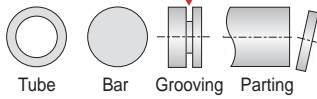

- Sharp cutting edge
- Low feed machining
- Small diameter component
- Low carbon steel
- Alloy steel
- Stainless

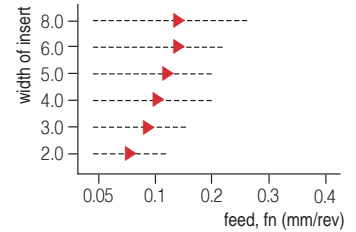

R For Rough Grooving

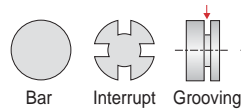
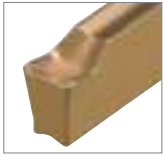

- Strong cutting edge
- High feed machining
- Interrupted cutting
- Carbon steel
- Alloy steel
- Stainless
- Cast iron

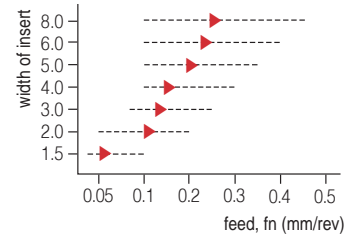

T For Turning and Multi Grooving

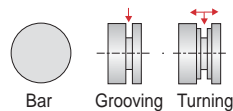

- Sharp cutting edge
- Improved chip control
- Turning & grooving machining
- Carbon steel
- Alloy steel
- Stainless
- Cast iron

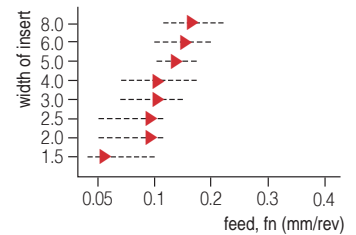

C For Copying and Relief

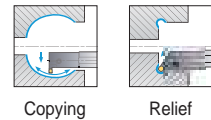

- Improved chip control
- Copying
- Relief
- Carbon steel
- Alloy steel
- Stainless
- Cast iron

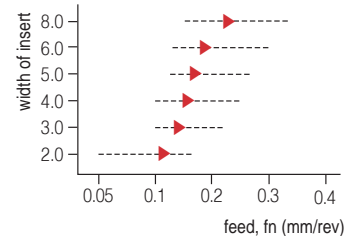

LP For Light Parting

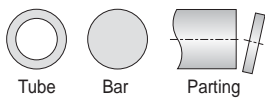

- Sharp cutting edge
- Low feed machining
- Small diameter component
- Right/left handed
- Low carbon steel
- Carbon steel
- Alloy steel
- Stainless

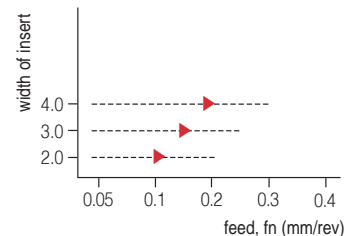

RP For Rough Parting

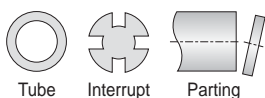

- Strong cutting edge
- High feed machining
- Interrupted cutting
- Right/left handed
- Carbon steel
- Alloy steel
- Cast iron

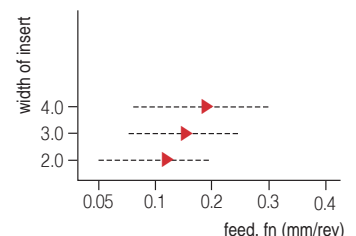

C Technical Information for KGT

B For Precision Grooving

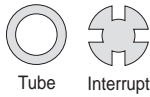

- Ground insert
- Precise tolerance
- Various cutting edge length, Nose R

- Carbon steel
- Alloy steel
- Stainless
- Cast iron

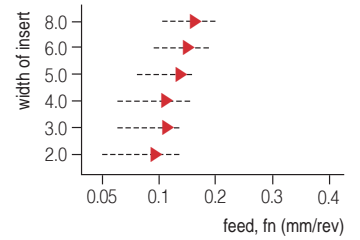

A For Aluminum Grooving

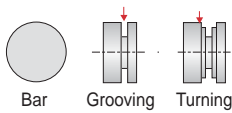

- Sharp cutting edge
- Precise tolerance

- Aluminum alloy
- Copper alloy

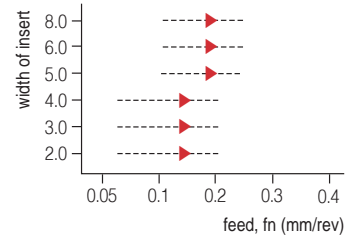

Grades for recommended application range

Workpiece	Grade	Order of recommended grade	Recommended cutting speed (m/min)					
			50	100	150	200	800	
P Steel Alloy Steel	PC5300	1		70	120			
	NC3225	2			130	220		
	NC5330	3			120	200		
	PC5300	1		60	105			
	NC3225	2			130	200		
	NC5330	3			90	180		
M Stainless steel	PC5300	1		70	120			
	PC9030	2		70	115			
	NC5330	3		75	125			
K Cast iron	PC5300	1		55	90			
	NC5330	2			95	160		
N Non-ferrous metal	H01	1				200	790	
S HRSA	PC5300	1	20	35				



Performance evaluation

Multi-function machining

Turning + Grooving repetition

Optimized geometry for turning + grooving - High efficiency.

- **Workpiece** SM45C
- **Cutting condition**
 - vc = 170 (m/min)
 - fn = 0.15 (mm/rev)
 - ap = 2 mm
 - W = 3 mm
 - wet
- **Designation** KGMN300-04-T (PC5300)

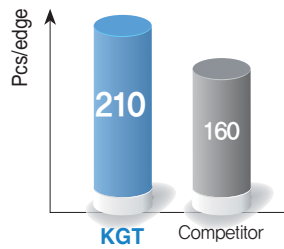

30% Up

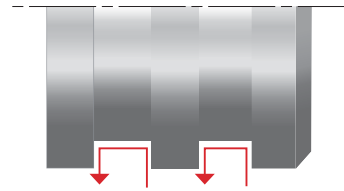

Grooving

Shoulder Grooving

Tough geometry for interrupted and deep grooving.

- **Workpiece** SUS304
- **Cutting condition**
 - vc = 120 (m/min)
 - fn = 0.12 (mm/rev)
 - ap = 5 mm
 - W = 4 mm
 - wet
- **Designation** KGMN400-03-R (PC5300)

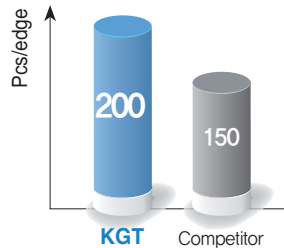

30% Up

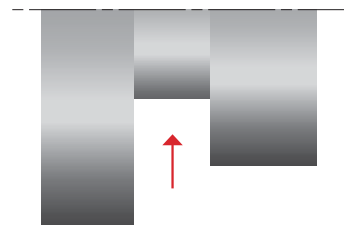

Shaft machining

Grooving (Roughing) & Turning (Finishing)

Excellent chip control for higher efficiency.

- **Workpiece** SCM440
- **Cutting condition**
 - vc = 150 (m/min)
 - fn = 0.15 (mm/rev)
 - ap = 5 mm
 - W = 3 mm x 3
 - wet
- **Designation** KGMN300-04-T (PC5300)

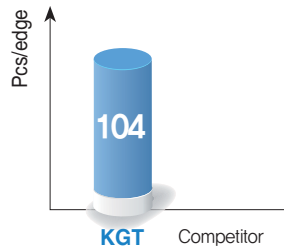

30% Up

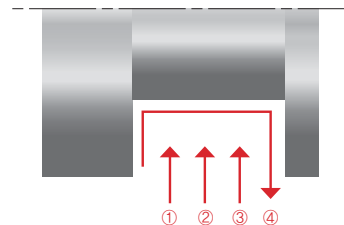

Parting off

Pipe Parting-off

Exclusive parting-off chip breaker for longer tool life. / Sharp geometry for less burr.

- **Workpiece** SUS304
- **Cutting condition**
 - vc = 140 (m/min)
 - fn = 0.15 (mm/rev)
 - ap = 2 mm
 - W = 3 mm
 - wet
- **Designation** KGMR300-6D-LP (PC5300)

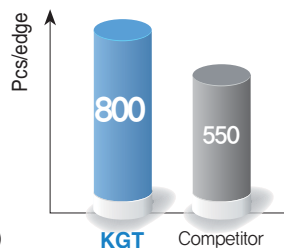



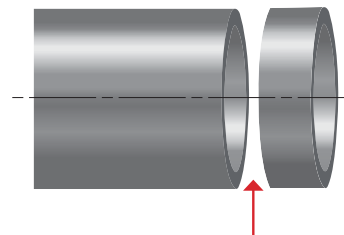





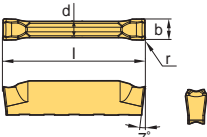

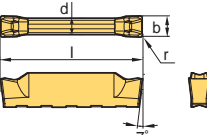

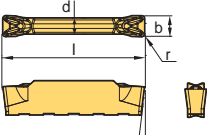

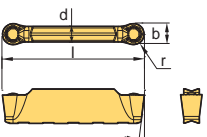
45% Up

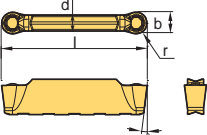

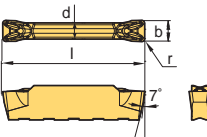
C Available Insert for KGT

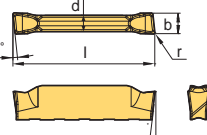
Insert

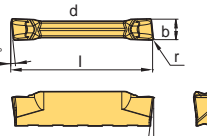









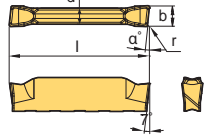

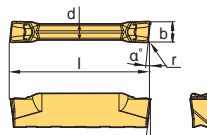

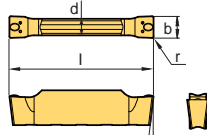
Application	Picture	Designation	Coated						Dimensions (mm)					Configuration	Page	
			NC3215	NC3225	NC5330	NC6315	PC5300	PC9030	b	r	l	d	α°			
Grooving		KGMN 200-02-L 300-02-L 400-02-L 500-03-L 600-03-L		●	●		●	●	2.0	0.2	20	1.7	-		C14~21 C23	
				●	●		●	●	3.0	0.2	20	2.3	-			
				●	●		●	●	4.0	0.2	20	3.3	-			
				●	●		●	●	5.0	0.3	25	4.1	-			
				●	●		●	●	6.0	0.3	25	5.1	-			
Grooving · Parting off		KGMN 150-015-R 200-02-R 300-02-R 400-03-R 500-03-R 600-03-R 800-04-R		●	●		●		1.5	0.15	16	1.2	-		C14~21 C23	
				●	●		●	●	2.0	0.2	20	1.7	-			
				●	●		●	●	3.0	0.2	20	2.3	-			
				●	●		●	●	4.0	0.3	20	3.3	-			
					●		●		5.0	0.3	25	4.1	-			
					●		●		6.0	0.3	25	5.1	-			
					●		●		8.0	0.4	30	6.1	-			
Grooving · Turning		KGMN 150-015-T 200-02-T 250-02-T 300-02-T 04-T 400-04-T 08-T 500-04-T 08-T 600-04-T 08-T 800-08-T		●	●	●	●		1.5	0.15	16	1.2	-		C14~21 C23	
				●	●	●	●	●	2.0	0.2	20	1.7	-			
				●	●		●		2.5	0.2	20	2.0	-			
				●	●	●	●	●	3.0	0.2	20	2.3	-			
				●	●	●	●	●	4.0	0.4	20	2.3	-			
				●	●	●	●	●	4.0	0.4	20	3.3	-			
				●	●	●	●	●	4.0	0.8	20	3.3	-			
				●	●	●	●	●	5.0	0.4	25	4.1	-			
				●	●	●	●	●	5.0	0.8	25	4.1	-			
				●	●	●	●	●	6.0	0.4	25	5.1	-			
				●	●	●	●	●	6.0	0.8	25	5.1	-			
Relief Profiling		KRMN 200-C 300-C 400-C 500-C 600-C 800-C		●	●	●	●		2.0	1.0	20	1.7	-		C14~22	
				●	●		●		3.0	1.5	20	2.2	-			
				●	●	●	●		4.0	2.0	20	3.2	-			
				●	●	●	●		5.0	2.5	25	4.0	-			
				●	●	●	●		6.0	3.0	25	5.0	-			
				●	●	●	●		8.0	4.0	30	6.0	-			
Profiling		KRMI 200-C 300-C 400-C							2.0	1.0	20	1.7	-		C23	
										3.0	1.5	20	2.2			-
										4.0	2.0	20	3.2			-
Grooving · Internal		KGMI 200-02-T 300-04-T 400-04-T					●		2.0	0.2	20	1.7	-		C23	
							●		3.0	0.4	20	2.3	-			
							●		4.0	0.4	20	3.3	-			
Parting off (Right handed)		KGMR 200-6D-LP 8D-LP 15D-LP 300-6D-LP 15D-LP 400-4D-LP 15D-LP 500-4D-LP			●		●		2.0	0.2	20	1.7	6		C14 C16	
										2.0	0.2	20	1.7			8
					●		●			2.0	0.2	20	1.7			15
					●		●			3.0	0.2	20	2.3			6
					●		●			3.0	0.2	20	2.3			15
					●		●			4.0	0.3	20	3.3			4
					●		●			4.0	0.3	20	3.3			15
Parting off (Right handed)		KGMR 200-6D-RP 8D-RP 15D-RP 300-6D-RP 15D-RP 400-4D-RP 15D-RP 500-4D-RP			●		●		2.0	0.2	20	1.7	6		C14 C16	
										2.0	0.2	20	1.7			8
					●		●			2.0	0.2	20	1.7			15
					●		●			3.0	0.2	20	2.3			6
					●		●			3.0	0.2	20	2.3			15
					●		●			4.0	0.3	20	3.3			4
					●		●			4.0	0.3	20	3.3			15

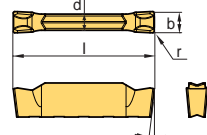
* You can grind the chip breaker, 'B' as any shape you want. If you want any special shape of chip breaker, please contact your distributor.

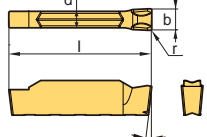
● : Stock item

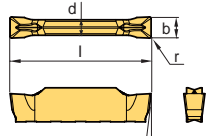

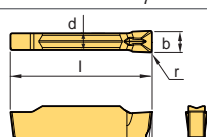
Insert

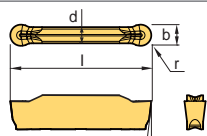
Application	Picture	Designation	Coated				Uncoated		Dimensions (mm)					Configuration	Page
			NC3215	NC5330	PC5300	PC9030	H01	H05	b	r	l	d	α°		
Parting off (Left handed)		KGML 200-6D-LP							2.0	0.2	20	1.7	6		C14 C16
		15D-LP							2.0	0.2	20	1.7	15		
		300-6D-LP							3.0	0.2	20	2.3	6		
		15D-LP							3.0	0.2	20	2.3	15		
		400-4D-LP							4.0	0.2	20	3.3	4		
		15D-LP							4.0	0.2	20	3.3	15		
Parting off (Right handed)		KGML 200-6D-RP							2.0	0.2	20	1.7	6		C14 C16
		15D-RP							2.0	0.2	20	1.7	15		
		300-6D-RP							3.0	0.2	20	2.3	6		
		15D-RP							3.0	0.2	20	2.3	15		
		400-4D-RP							4.0	0.2	20	3.3	4		
		15D-RP							4.0	0.2	20	3.3	15		
Grooving (Ground insert)		KGGN 265-015-B							2.65	0.15	20	2.3	-		C14 C16-18
		300-020-B							3.0	0.20	20	2.3	-		
		040-B							3.0	0.40	20	2.3	-		
		315-015-B							3.15	0.15	20	2.3	-		
		400-040-B							4.0	0.40	20	3.3	-		
		080-B							4.0	0.80	20	3.3	-		
		415-015-B							4.15	0.15	20	3.3	-		
		478-055-B							4.78	0.55	20	3.3	-		
		500-080-B							5.0	0.80	25	4.1	-		
		515-015-B							5.15	0.15	25	4.1	-		
		600-080-B							6.0	0.80	25	5.1	-		
		120-B							6.0	1.20	25	5.1	-		
		800-080-B							8.0	0.80	30	6.1	-		
		120-B							8.0	1.20	30	6.1	-		
Grooving - Parting off (Ground insert)		KGGN 200-02-R							2.0	0.2	20	1.7	-		C14-21
		300-02-R							3.0	0.2	20	2.3	-		
		400-03-R							4.0	0.3	20	3.3	-		
		500-03-R							5.0	0.3	25	4.1	-		
		600-03-R							6.0	0.3	25	5.1	-		
		800-04-R							8.0	0.4	30	6.1	-		
Grooving - Parting off (Single insert)		KGGN 200S-02-R							2.0	0.2	19.9	1.7	-		C24
		300S-02-R			●				3.0	0.2	19.9	2.3	-		
		400S-03-R			●				4.0	0.3	19.9	3.3	-		
		500S-03-R			●				5.0	0.3	24.9	4.1	-		
		600S-03-R			●				6.0	0.3	24.9	5.1	-		
		800S-04-R			●				8.0	0.4	24.9	6.1	-		
Aluminum Grooving		KGGN 200-02-A					●		2.0	0.2	20	1.7	-		C14-21
		300-02-A					●		3.0	0.2	20	2.3	-		
		400-04-A					●		4.0	0.4	20	3.3	-		
		500-04-A					●		5.0	0.4	25	4.1	-		
		600-04-A					●		6.0	0.4	25	5.1	-		
Aluminum Grooving (Single insert)		KGGN 200S-02-A							2.0	0.2	20	1.7	-		C24
		300S-02-A							3.0	0.2	20	2.3	-		
		400S-04-A							4.0	0.4	20	3.3	-		
		500S-04-A							5.0	0.4	25	4.1	-		
		600S-04-A							6.0	0.4	25	5.1	-		
Aluminum Grooving		KRGN 300-A					●		3.0	1.5	20	2.3	-		C14-21
		400-A					●		4.0	2.0	20	3.3	-		
		500-A					●		5.0	2.5	25	4.1	-		
		600-A					●		6.0	3.0	25	5.1	-		
		800-A					●		8.0	4.0	30	6.1	-		

• You can grind the chip breaker, 'B' as any shape you want. If you want any special shape of chip breaker, please contact your distributor.

● : Stock item



KGEHR/L

For grooving, turning, parting off, and relief machining



KGGN
 KGMR/L
 KRGN

KGMN
 KRMN

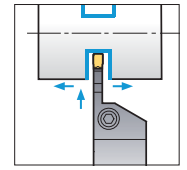
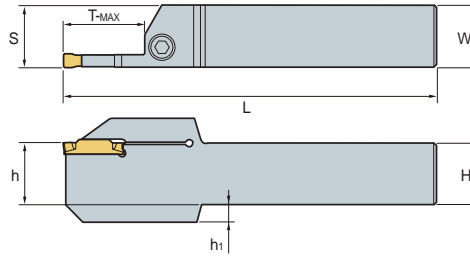
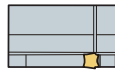

• R type insert (mm)

Designation		H = (h)	W	L	S	h1	T-MAX	Inserts	Screw	Wrench
KGEHR/L	1616-1.5-T14	16	16	100	16.2	-	14	KGMN150-□-□	MHA0512	HW40L
	2020-1.5-T14	20	20	125	20.2	-	14			
	2525-1.5-T14	25	25	150	25.2	-	14			
	1212-2-T08	12	12	100	12.2	-	8	KGMN200-□-□ KGMR/L200-□-□ KRMN200-C KGGN200-□-□	MHA0512	HW40L
	1616-2-T08	16	16	100	16.2	-	8			
	2020-2-T08	20	20	125	20.2	-	8			
	2525-2-T08	25	25	150	25.2	-	8			
	1616-2-T12	16	16	100	16.2	-	12			
	2020-2-T12	20	20	125	20.2	-	12			
	2525-2-T12	25	25	150	25.2	-	12			
	1616-2-T17	16	16	100	16.2	-	17			
	2020-2-T17	20	20	125	20.2	-	17			
	2525-2-T17	25	25	150	25.2	-	17			
	1616-2.5-T17	16	16	100	16.3	-	17	KGMN250-□-□	MHA0512	HW40L
	2020-2.5-T17	20	20	125	20.3	-	17			
	2525-2.5-T17	25	25	150	25.3	-	17			
	1616-3-T10	16	16	100	16.4	-	10	KGMN300-□-□ KGMR/L300-□-□ KRMN300-C KGGN300-□-□ KRGN300-□	MHA0512	HW40L
	2020-3-T10	20	20	125	20.4	-	10			
	2525-3-T10	25	25	150	25.4	-	10			
	3232-3-T10	32	32	170	32.4	-	10			
	1616-3-T13	16	16	100	16.4	-	13			
	2020-3-T13	20	20	125	20.4	-	13			
	2525-3-T13	25	25	150	25.4	-	13			
	1616-3-T20	16	16	100	16.4	-	20			
	2020-3-T20	20	20	125	20.4	-	20			
	2525-3-T20	25	25	150	25.4	-	20			
	3232-3-T20	32	32	170	32.4	-	20	KGMN400-□-□ KGMR/L400-□-□ KRMN400-C KGGN400-□-□ KRGN400-□	BHA0616	HW50L
2525-3-T25	25	25	150	25.4	-	25				
1616-4-T10	16	16	100	16.4	-	10				
2020-4-T10	20	20	125	20.4	-	10				
2525-4-T10	25	25	150	25.4	-	10				
3232-4-T10	32	32	150	32.4	-	10				
1616-4-T15	16	16	100	16.4	-	15				
2020-4-T15	20	20	125	20.4	-	15				
2525-4-T15	25	25	150	25.4	-	15				
1616-4-T20	16	16	100	16.4	-	20				
2020-4-T20	20	20	125	20.4	-	20				
2525-4-T20	25	25	150	25.4	-	20				
3232-4-T20	32	32	170	32.4	-	20				
1616-4-T25	16	16	100	16.4	-	25				
2020-4-T25	20	20	125	20.4	-	25				
2525-4-T25	25	25	150	25.4	-	25				

Applicable inserts C12~C13



KGEHR/L

For grooving, turning, parting off, and relief machining



KGGN KGMN
KGMR/L KRMN
KRGN

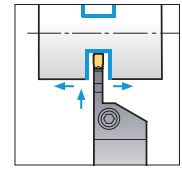
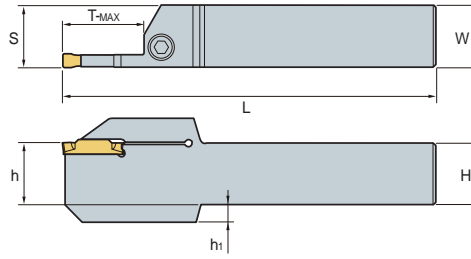
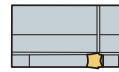

• R type insert
(mm)

Designation		H = (h)	W	L	S	h ₁	T-MAX	Inserts	Screw	Wrench		
KGEHR/L	2020-5-T12	20	20	125	20.5	-	12	KGMN500-□-□ KRMN500-C KGGN500-□-□ KRGN500-□	BHA0616	HW50L		
	2525-5-T12	25	25	150	25.5	-	12					
	2020-5-T15	20	20	125	20.55	-	15					
	2525-5-T15	25	25	150	25.55	-	15					
	3232-5-T15	32	32	170	32.55	-	15					
	2020-5-T20	20	20	125	20.5	-	20					
	2525-5-T20	25	25	150	25.5	-	20					
	3232-5-T20	32	32	170	32.5	-	20					
	2525-5-T32	25	25	150	25.5	7	32				BHA0620	HW50L
	2020-6-T12	20	20	125	20.5	-	12				KGMN600-□-□ KRMN600-C KGGN600-□-□ KRGN600-□	BHA0616
	2525-6-T12	25	25	150	25.5	-	12					
	2525-6-T15	25	25	150	25.55	-	15					
	3232-6-T15	32	32	170	32.55	-	15					
	2020-6-T20	20	20	125	20.5	-	20					
	2525-6-T20	25	25	150	25.5	-	20					
	3232-6-T20	32	32	170	32.5	-	20					
	2525-6-T32	25	25	150	25.5	7	32	BHA0620	HW50L			
	2525-8-T16	25	25	150	26	-	16	KGMN800-□-□ KRMN800-C KGGN800-□-□ KRGN800-□	BHA0616	HW50L		
	3232-8-T16	32	32	170	33.05	-	16					
	2525-8-T25	25	25	150	26	-	25					
3232-8-T25	32	32	170	33	-	25						
2525-8-T36	25	25	150	26	7	36	BHA0620				HW50L	
3232-8-T36	32	32	170	33	-	36						

➔ Applicable inserts C12~C13

KGEHR/L-D00A (Auto Tool)

For grooving, turning, parting off machining



KGGN KGMN
KGMR/L KRMN

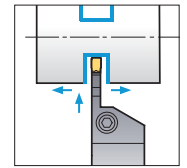
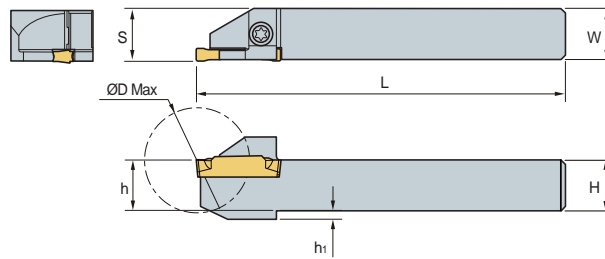

• R type insert

(mm)

Designation	H = (h)	W	L	S	h ₁	ØD Max	Inserts	Screw	Wrench	
KGEHR/L	1010-2-D20A	10	10	125	10.2	2	20	KGMN200-□-□ KGMR/L200-□-□ KRMN200-C KGGN200-□-□	ETNA0412	TW15L
	1212-2-D25A	12	12	125	12.2	2	25			
	1414-2-D25A	14	14	125	14.2	-	25			
	1616-2-D32A	16	16	125	16.2	-	32			
	1212-3-D25A	12	12	125	12.4	2	25			
	1616-3-D32A	16	16	125	16.4	-	32			

➔ Applicable inserts C12~C13

KGEHR/L-D00B (Auto Tool)

For grooving, turning, parting off machining



KGGN KGMN
KRMN KGMR/L

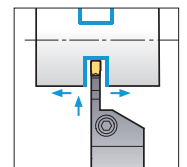
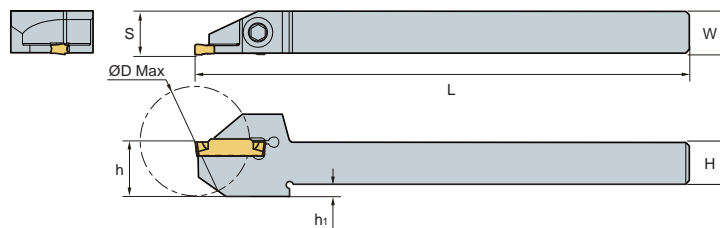

• R type insert

(mm)

Designation	H = (h)	W	L	S	h ₁	ØD Max	Inserts	Screw	Wrench	
KGEHR/L	1010-2-D30B	10	10	140	10.2	6.6	30	KGMN200-□-□ KGMR/L200-□-□ KRMN200-C KGGN200-□-□	MHA0512	HW40L
	1212-2-D25B	12	12	140	12.5	3.5	25			
	1212-2-D30B	12	12	140	12.2	3.5	30			
	1616-2-D25B	16	16	140	16.2	-	25			
	1616-2-D32B	16	16	140	16.2	-	32			
	1212-3-D25B	12	12	140	12.4	3.5	25	KGMN300-□-□ KGMR/L300-□-□ KRMN300-C KGGN300-□-□		
	1212-3-D32B	12	12	140	12.4	3.5	32			
	1616-3-D25B	16	16	140	16.4	-	25			
	1616-3-D32B	16	16	140	16.4	-	32			

➔ Applicable inserts C12~C13



KGEHR/L-T00

For grooving, turning, face grooving machining



KGMN KRMN
KGGN KRGN

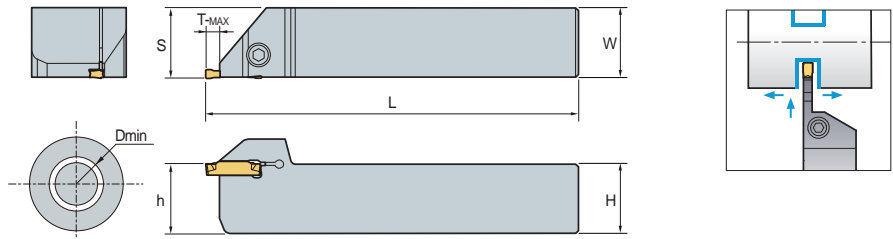

• R type insert
(mm)

Designation		H = (h)	W	L	S	ØD Min	T-MAX	Inserts	Screw	Wrench
KGEHR/L	1616-3-T00	16	16	100	16.4	80	4.8	KGMN300-□-□ KRMN300-C KGGN300-□-□ KRGN300-□	MHA0512	HW40L
	2020-3-T00	20	20	125	20.4	80	4.8			
	2525-3-T00	25	25	150	25.4	80	4.8			
	1616-4-T00	16	16	100	16.4	80	4.8	KGMN400-□-□ KRMN400-C KGGN400-□-□ KRGN400-□	BHA0616	HW50L
	2020-4-T00	20	20	125	20.4	80	4.8			
	2525-4-T00	25	25	150	25.4	80	4.8			
	2020-6-T00	20	20	125	20.5	80	6.0	KGMN600-□-□ KRMN600-C KGGN600-□-□ KRGN600-□	BHA0616	HW50L
	2525-6-T00	25	25	150	25.5	80	6.0			

↻ Applicable inserts C12~C13

KGEVR/L-T00

For grooving, turning, face grooving machining



KGMN
KRGV

KRMN
KGGN

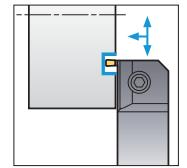
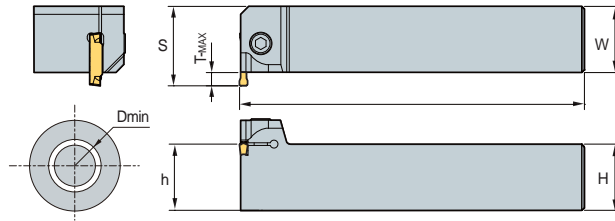

• R type insert

Designation		H = (h)	W	L	S	ØD Min	T-MAX	Inserts	Screw	Wrench
KGEVR/L	2020-1.5 -T00	20	20	125	23.5	120	3	KGMN150-□-□	MHA0512	HW40L
	2525-1.5 -T00	25	25	150	28.5	120	3			
	3232-1.5 -T00	32	32	170	35.5	120	3			
	2020-2 -T00	20	20	125	23.5	120	3	KGMN200-□-□ KRMN200-C KGGN200-□-□-□	MHA0512	HW40L
	2525-2 -T00	25	25	150	28.5	120	3			
	3232-2 -T00	32	32	170	35.5	120	3			
	2020-2.5 -T00	20	20	125	24.5	80	4	KGMN250-□□	MHA0512	HW40L
	2525-2.5 -T00	25	25	150	29.5	80	4			
	3232-2.5 -T00	32	32	170	36.5	80	4			
	2020-3-T00	20	20	125	25	80	4.8	KGMN300-□-□ KRMN300-C KGGN300-□-□	MHA0512	HW40L
	2525-3-T00	25	25	150	30	80	4.8			
	3232-3 -T00	32	32	170	37	80	4.8			
	2020-4-T00	20	20	125	25	80	4.8	KGMN400-□-□ KRMN400-C KGGN400-□-□	BHA0616	HW50L
	2525-4-T00	25	25	150	30	80	4.8			
	3232-4 -T00	32	32	170	37	80	4.8			
	2020-5 -T00	20	20	125	29.5	60	6	KGMN500-□-□ KRMN500-C KGGN500-□-□	BHA0616	HW50L
	2525-5 -T00	25	25	150	31.5	60	6			
	3232-5 -T00	32	32	170	38.5	60	6			
	2020-6 -T00	20	20	125	26.5	60	6	KGMN600-□-□ KRMN600-C KGGN600-□-□	BHA0616	HW50L
	2525-6-T00	25	25	150	31.5	80	6			
	3232-6 -T00	32	32	170	38.5	60	6			
	2525-8 -T00	25	25	150	33.5	50	8	KGMN800-□-□ KRMN800-C KGGN800-□-□	BHA0616	HW50L
	3232-8 -T00	32	32	170	38.5	50	8			

↻ Applicable inserts C12~C13

KGEUR/L



KRMN
KRGN

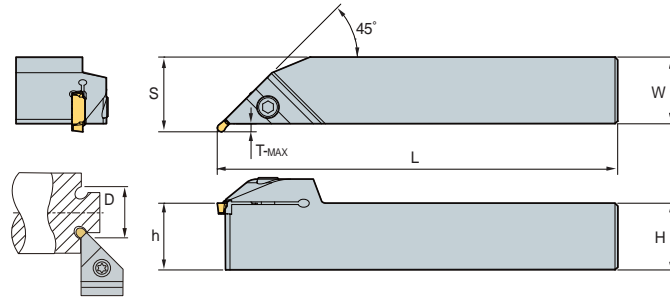

For relief machining

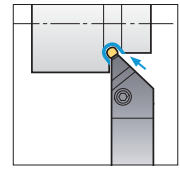

• R type insert
(mm)

Designation		H = (h)	W	L	S	ØD Min	T-MAX	Inserts	Screw	Wrench
KGEUR/L	1616-3	16	16	100	19	40	2.8	KRMN300-C KRGN300-□	MHA0512	HW40L
	2020-3	20	20	125	23	40	2.8			
	2525-3	25	25	150	28	40	2.8			
	3232-3	32	32	170	35	40	2.8	KRMN400-C KRGN400-□	BHA0616	HW50L
	1616-4	16	16	100	19	40	2.8			
	2020-4	20	20	125	23	40	2.8			
	2525-4	25	25	150	28	40	2.8	KRMN500-C KRGN500-□	BHA0616	HW50L
	3232-4	32	32	170	35	40	2.8			
	2020-5	20	20	125	23.5	50	3.3			
	2525-5	25	25	150	28.5	50	3.3	KRMN600-C KRGN600-□	BHA0616	HW50L
	3232-5	32	32	170	35.5	50	3.3			
	2020-6	20	20	125	23.5	50	3.3			
	2525-6	25	25	150	28.5	50	3.3	KRMN800-C KRGN800-□	BHA0616	HW50L
	3232-6	32	32	170	35.5	50	3.3			
	2525-8	25	25	150	28.5	65	3.3			
	3232-8	32	32	170	35.5	65	3.3			

↻ Applicable inserts C12~C13

KGFR/L

For face grooving machining



KGMN KGMN
KGGN KGGN
KRMN KRMN
KRGV KRGV

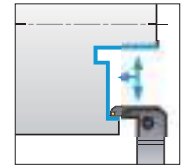
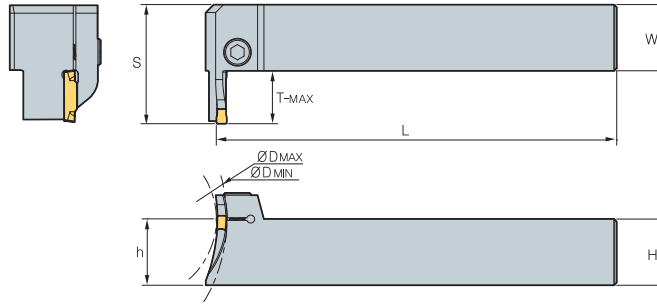

• R type insert

(mm)

Designation	H = (h)	W	L	S	T-MAX	ØD		Inserts	Screw	Wrench	
						Min	Max				
KGFVR/L 325-34/50-T10	25	25	150	36	10	34	50	KGMN300-□-□	MHA0512	HW40L	
	44/60-T15	25	25	150	41	15	44	60			KRMN300-C
	54/85-T15	25	25	150	41	15	54	85			KGGN300-□-□ KRGV300-□
425-32/50-T15	25	25	150	41	15	32	50	KGMN400-□-□ KRMN400-C KGGN400-□-□ KRGV400-□	BHA0616	HW50L	
	42/60-T15	25	25	150	41	15	42				60
	44/70-T20	25	25	150	45.5	20	44				70
	52/85-T15	25	25	150	41	15	52				85
	60/120-T20	25	25	150	45.5	20	60				120
112/200-T20	25	25	150	45.5	20	112	200				
525-50/80-T20	25	25	150	46	20	50	80	KGMN500-□-□ KRMN500-C KGGN500-□-□ KRGV500-□	BHA0616	HW50L	
	70/110-T20	25	25	150	46	20	70				110
	100/150-T20	25	25	150	46	20	100				150
	140/200-T20	25	25	150	46	20	140				200
	200-T20	25	25	150	46	20	200				∞
625-48/85-T20	25	25	150	46	20	48	85	KGMN600-□-□ KRMN600-C KGGN600-□-□ KRGV600-□	BHA0616	HW50L	
	73/150-T20	25	25	150	46	20	73				150
	138/250-T20	25	25	150	46	20	138				250
	250-T20	25	25	150	46	20	250				∞

Applicable inserts C12~C13

KGFHR/L

For face grooving machining



KGMN
KGGN KRMN
KRGN

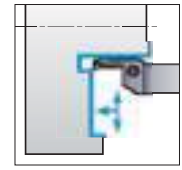
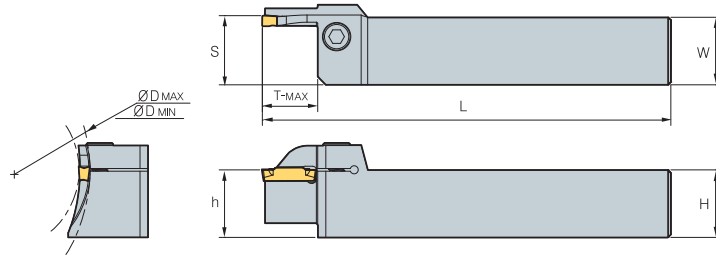

• R type insert
(mm)

Designation	H = (h)	W	L	S	T-MAX	ØD		Inserts	Screw	Wrench	
						Min	Max				
KGFHR/L 320-34/50-T10	20	20	150	20.5	10	34	50	KGMN300-□-□ KRMN300-C KGGN300-□-□ KRGN300-□	MHA0512	HW40L	
	44/70-T15	20	20	150	20.5	15	44				70
	64/100-T15	20	20	150	20.5	15	64				100
325-34/50-T10	25	25	150	25.5	10	34	50	KGMN300-□-□ KRMN300-C KGGN300-□-□ KRGN300-□	MHA0512	HW40L	
	44/70-T15	25	25	150	25.5	15	44				70
	64/100-T15	25	25	150	25.5	15	64				100
420-34/50-T16	20	20	150	20.5	16	34	50	KGMN400-□-□ KRMN400-C KGGN400-□-□ KRGN400-□	BHA0616	HW50L	
	42/70-T16	20	20	150	20.5	16	42				70
	62/120-T16	20	20	150	20.5	16	62				120
	112/200-T16	20	20	150	20.5	16	112				200
425-34/50-T20	25	25	150	25.6	20	34	50	KGMN400-□-□ KRMN400-C KGGN400-□-□ KRGN400-□	BHA0616	HW50L	
	40/60-T10	25	25	150	25.6	10	40				60
	44/70-T20	25	25	150	25.6	20	44				70
	84/92-T20	25	25	150	25.6	20	84				92
	60/120-T20	25	25	150	25.6	20	60				120
	112/200-T20	25	25	150	25.6	20	112				200
200-T20	25	25	150	25.6	20	200	∞	KGMN400-□-□ KRMN400-C KGGN400-□-□ KRGN400-□	BHA0616	HW50L	
	25	25	150	25.6	20	200	∞				
525-50/80-T15	25	25	150	25.6	15	50	80	KGMN500-□-□ KRMN500-C KGGN500-□-□ KRGN500-□	BHA0616	HW50L	
	50/80-T25	25	25	150	25.6	25	50				80
	70/110-T15	25	25	150	25.6	15	70				110
	70/110-T25	25	25	150	25.6	25	70				110
	100/150-T25	25	25	150	25.6	25	100				150
	140/200-T25	25	25	150	25.6	25	140				200
	190/220-T10	25	25	150	25.6	10	190				200
200-T25	25	25	150	25.6	25	200	∞	KGMN500-□-□ KRMN500-C KGGN500-□-□ KRGN500-□	BHA0616	HW50L	
	25	25	150	25.6	25	200	∞				
625-170/190-T10	25	25	150	25.6	10	170	190	KGMN600-□-□ KRMN600-C KGGN600-□-□ KRGN600-□	BHA0616	HW50L	
	190/220-T10	25	25	150	25.6	10	190				200

↻ Applicable inserts C12~C13

KGIUR/L

For relief machining



KRMN
KRGN

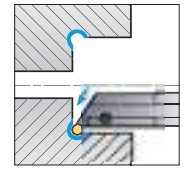
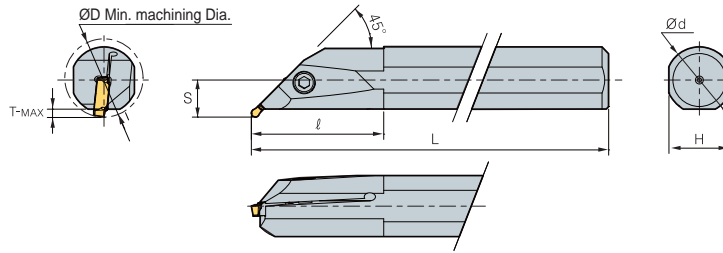

• R type insert
(mm)

Designation		ØD	Ød	L	ℓ	T-MAX	H	S	Inserts	Screw	Wrench
KGIUR/L	3520-3	35	20	150	45	3.5	18	13	KRMN300-C KRGN300-□	MHA0512	HW40L
	4025-3	40	25	200	50	3.5	23	15.5			
	5032-3	50	32	250	65	3.5	30	19			
	3520-4	35	20	150	45	3.5	18	13	KRMN400-C KRGN400-□	MHA0512	HW40L
	4025-4	40	25	200	50	3.5	23	15.5			
	5032-4	50	32	250	65	3.5	30	19			
	4025-5	40	25	200	50	3.5	23	15.5	KRMN500-C KRGN500-□	MHA0512	HW40L
	5032-5	50	32	250	65	3.5	30	19			
	4025-6	40	25	200	50	3.5	23	15.5	KRMN600-C KRGN600-□	MHA0512	HW40L
	5032-6	50	32	250	65	3.5	30	19			
	4025-8	40	25	200	50	3.5	23	18.5	KRMN800-C KRGN800-□	MHA0512	HW40L
	5032-8	50	32	250	65	3.5	30	22			

↻ Applicable inserts C12~C13

KGIVR/L

For grooving, turning and profil machining

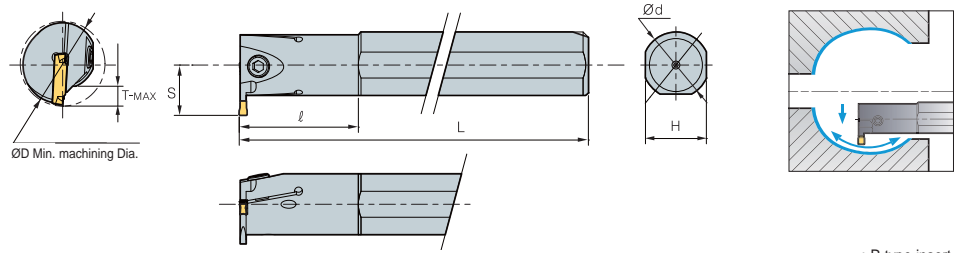

KGMI
KGGN
KRMN

KGMN
KRMI

• R type insert
(mm)

Designation		ØD	Ød	L	ℓ	T-MAX	H	S	Inserts	Screw	Wrench
KGIVR/L	2016-1.5	20	16	125	35	4	15	12	KGMN150-□-□	MHB0410	HW30L
	2520-1.5	25	20	150	45	6	18	15.5		MHB0410	
	3225-1.5	32	25	200	45	7	23	19		MHA0512	HW40L
	2516-2	25	16	125	35	6.5	15	14	KGMI200-□-T KRMI200-C	MHB0410	HW30L
	2520-2	25	20	150	45	6.5	18	15.5		MHB0512	HW40L
	3225-2	32	25	200	45	7	23	19		MHB0512	HW40L
	2516-2.5	25	16	125	35	6.5	15	14	KGMN250-□-□	MHB0410	HW30L
	2520-2.5	25	20	150	45	6.5	18	15.5		MHB0410	HW30L
	3225-2.5	32	25	200	45	7	23	19		MHA0512	HW40L
	2520-3	25	20	150	45	6.5	18	15.5	KGMI300-□-T KRMI300-C	MHB0410	HW30L
	3225-3	32	25	200	45	7	23	19		MHA0512	HW40L
	4032-3	40	32	250	55	7.5	30	22.5		BHA0616	HW50L
	2520-4	25	20	150	45	6.5	18	15.5	KGMI400-□-T KRMI400-C	MHB0410	HW30L
	3225-4	32	25	200	45	7	23	19		MHA0512	HW40L
	4032-4	40	32	250	55	7.5	30	22.5		BHA0616	HW50L
	3225-5	32	25	200	45	7.5	23	19.5	KGMN500-□-□ KRMN500-C	MHA0512	HW40L
4032-5	40	32	250	55	8.5	30	23.5	KGGN500-□-R KGGN500-□-A		BHA0616	HW50L
3225-6	32	25	200	45	7.5	23	19.5	KGMN600-□-□ KRMN600-C	MHA0512	HW40L	
4032-6	40	32	250	55	8.5	30	23.5		KGGN600-□-R KGGN600-□-A	BHA0616	HW50L
4032-8	40	32	250	55	8.5	30	23.5	KGMN800-□-□ KRMN800-C	BHA0616	HW50L	
4540-8	45	40	300	70	8.5	37	26.5		KGGN800-□-R	BHA0616	HW50L

➡ Applicable inserts C12~C13

• 200, 300, 400 inserts : Internal inserts, KGMI or KRMI

KGT Blade for Parting off

Features

- Parting application with the use of existing KGT inserts
- Economical machining with a double sided insert
- Specially designed slot for strong and stable clamping
- Easy change of insert with the use of exclusive wrench

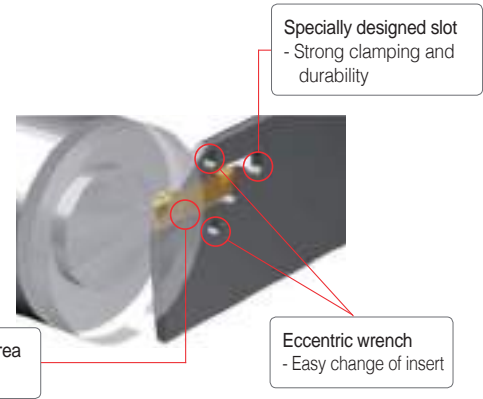

Holder Code system



How to clamp insert

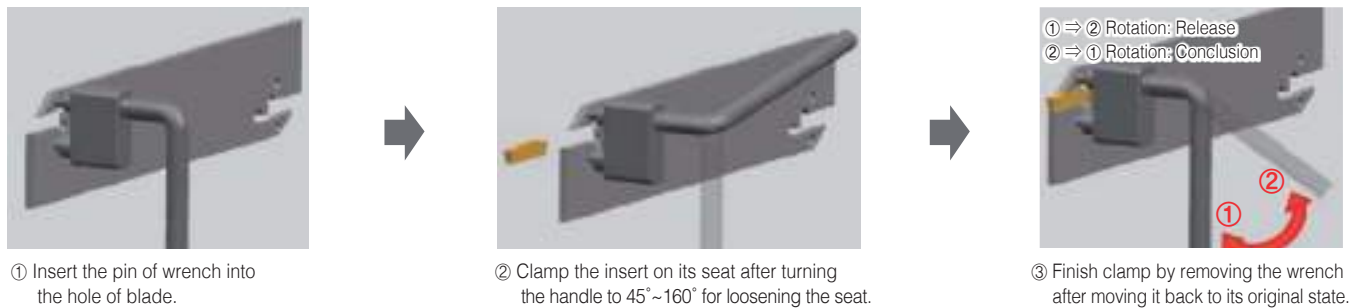

KGTB

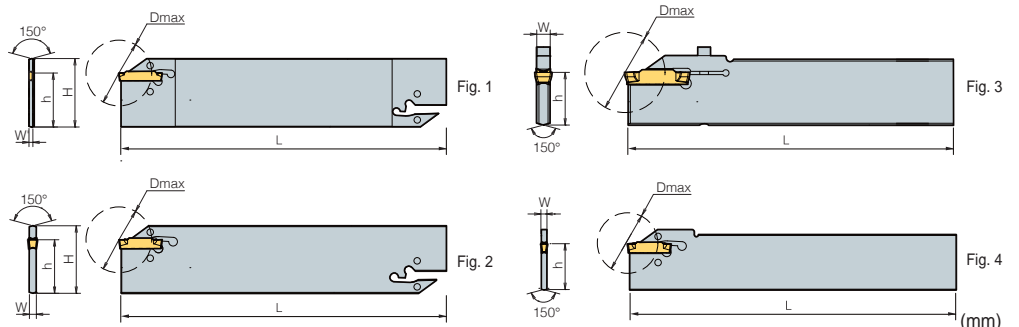

Designation	H	W	W'	L	h	ØD Max ⁽²⁾	ØD Max ⁽³⁾	Inserts	Wrench	Fig
KGTB 1526S	26	2.4	1.0	150	21	-	26	KG□□150-□-□	EW1203 (Separately ordered)	4
1532	32	2.4	1	150	25	-	26	KG□□150-□-□		1
2026S	26	2.4	1.8	150	21	50	39	KG□□200-□-□ KG□□200S-□-□ ⁽⁴⁾		4
2032	32	2.4	1.8	150	25	50	39	KG□□200-□-□ KG□□200S-□-□ ⁽⁴⁾		1
3026S	26	2.4	-	150	21	100	39	KG□□300-□-□ KG□□300S-□-□ ⁽⁴⁾		4
3032	32	2.4	-	150	25	100	39	KG□□300-□-□ KG□□300S-□-□ ⁽⁴⁾		2
4026S	26	3.2	-	150	21	100	39	KG□□400-□-□ KG□□400S-□-□ ⁽⁴⁾		4
4032	32	3.2	-	150	25	100	39	KG□□400-□-□ KG□□400S-□-□ ⁽⁴⁾		2
5032	32	4	-	150	25	120	49	KG□□500-□-□ KG□□500S-□-□ ⁽⁴⁾		2
6032	32	5.2	-	150	25	120	49	KG□□600-□-□ KG□□600S-□-□ ⁽⁴⁾		2
8032S⁽¹⁾	32	6.2	-	150	25	80	59	KG□□800-□-□ KG□□800S-□-□ ⁽⁴⁾	HW30L	3

Applicable inserts C12~C13

⁽¹⁾ Screw clamping ⁽²⁾ 1 corner use ⁽³⁾ 2 corner use ⁽⁴⁾ 1 corner insert

